

STRAND I: Geometry and Trigonometry

Unit 35 *Trigonometric Problems*

Student Text

Contents

Section	
35.1	Mixed Problems Using Trigonometry
35.2	Sine and Cosine Rules
35.3	Application: Area of Any Triangle

35 Trigonometric Problems

35.1 Mixed Problems Using Trigonometry

When you look *up* at something, such as an aeroplane, the angle between your line of sight and the horizontal is called the *angle of elevation*.

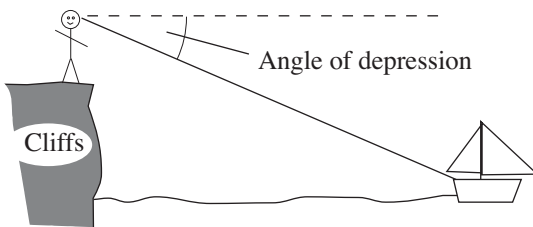
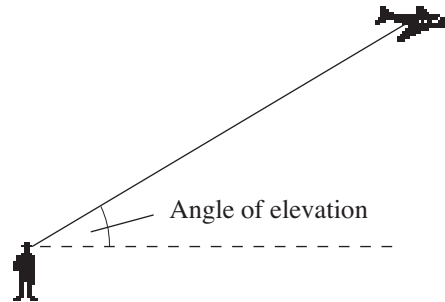

Similarly, if you look *down* at something, then the angle between your line of sight and the horizontal is called the *angle of depression*.



Worked Example 1

A man looks out to sea from a cliff top at a height of 12 metres. He sees a boat that is 150 metres from the cliffs. What is the angle of depression?



Solution

The situation can be represented by the triangle shown in the diagram, where θ is the angle of depression.

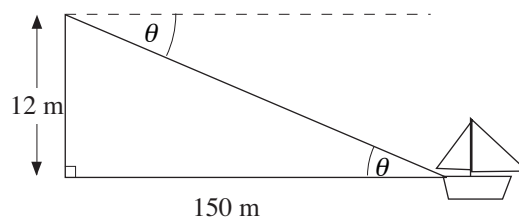

In this triangle,

$$\text{opposite} = 12 \text{ m}$$

$$\text{adjacent} = 150 \text{ m}$$

Using

$$\tan \theta = \frac{\text{opposite}}{\text{adjacent}}$$

gives

$$\begin{aligned} \tan \theta &= \frac{12}{150} \\ &= 0.08 \end{aligned}$$

Using a calculator gives $\theta = 4.6^\circ$ (to 1 d.p.)



Worked Example 2

A person walking on open land can see the top of a radio mast. The person is 200 metres from the mast. The angle of elevation of the top of the mast is 3° . What is the height of the mast?



Solution

The triangle illustrates the situation described.

In this triangle, opposite = x
 adjacent = 200 m

Using $\tan \theta = \frac{\text{opposite}}{\text{adjacent}}$

gives $\tan 3^\circ = \frac{x}{200}$

Multiplying both sides by 200 gives

$$\begin{aligned} x &= 200 \times \tan 3^\circ \\ &= 10.5 \text{ metres} \quad (\text{to 1 d.p.}) \end{aligned}$$

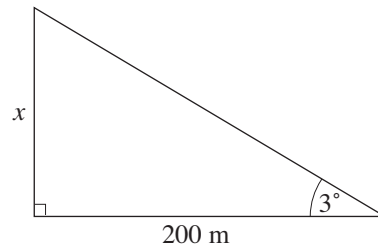

Worked Example 3

A ladder is 3.5 metres long. It is placed against a vertical wall so that its foot is on horizontal ground and it makes an angle of 48° with the ground.

- Draw a diagram which represents the information given. Label the diagram showing the ladder, the wall and the ground and insert all measurements given.
- Calculate, to two significant figures,
 - the height the ladder reaches up the wall
 - the distance the foot of the ladder is from the wall.
- The top of the ladder is lowered so that it reaches 1.75 m up the wall, still touching the wall.

Calculate the angle that the ladder now makes with the horizontal.

(CXC)



Solution

(a)

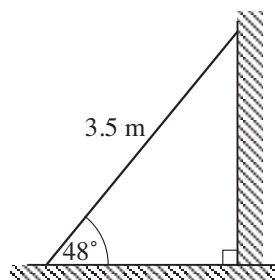

- (b) (i) height = $3.5 \sin 48^\circ$
 ≈ 2.601
 = 2.6 m to 2 significant figures
- (ii) distance = $3.5 \cos 48^\circ$
 ≈ 2.342
 = 2.3 m to 2 significant figures

(c)

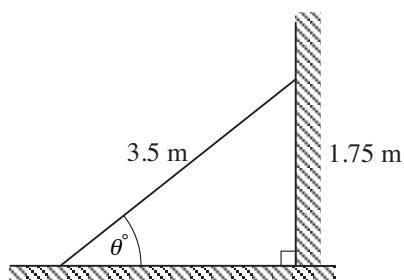

$$\begin{aligned}\sin \theta &= \frac{1.75}{3.5} \\ &= 0.5 \\ \theta &= 30^\circ\end{aligned}$$



Exercises

- In order to find the height of a tree, some students walk 50 metres from the base of the tree and measure the angle of elevation as 10° . Find the height of the tree.
- From a distance of 20 metres from its base, the angle of elevation of the top of a pylon is 32° . Find the height of the pylon.
- The height of a church tower is 15 metres. A man looks at the tower from a distance of 120 metres. What is the angle of elevation of the top of the tower from the man?
- A coastguard looks out from an observation tower of height 9 metres and sees a boat in distress at a distance of 500 metres from the tower. What is the angle of depression of the boat from the tower?
- A lighthouse is 20 metres high. A life-raft is drifting and one of its occupants estimates the angle of elevation of the top of the lighthouse as 3° .
 - Use the estimated angle to find the distance of the life-raft from the lighthouse.
 - If the life-raft is in fact 600 metres from the lighthouse, find the correct angle of elevation.
- A radio mast is supported by two cables as shown. Find the distance between the two points A and B.

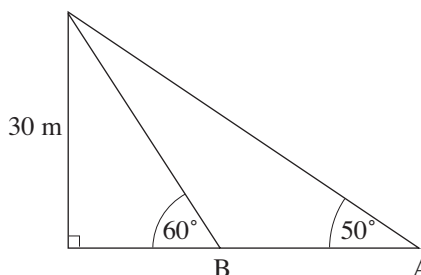
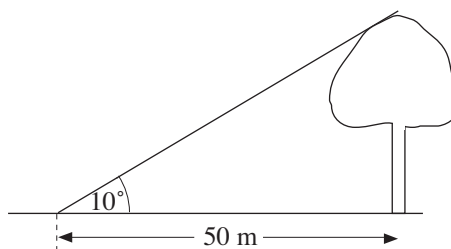

7. A man stands at a distance of 8 metres from a lamppost. When standing as shown, he measures the angle of elevation as 34° . Find the height of the lamppost.

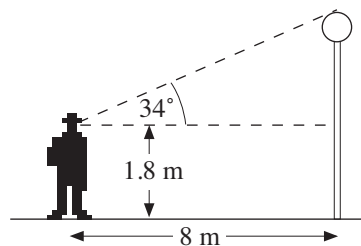

8. Find the unknown length (x) in each diagram.

(a)

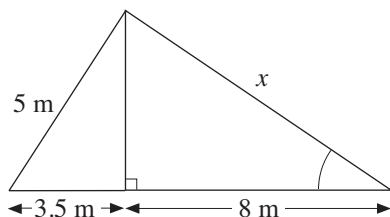

(b)

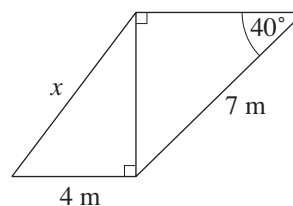

(c)

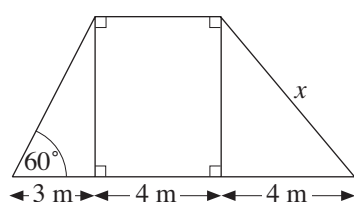

(d)

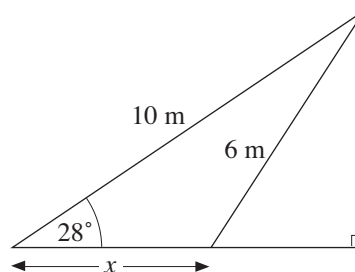

9. From his hotel window a tourist has a clear view of a clock tower. The window is 5 metres above ground level. The angle of depression of the bottom of the tower is 5° and the angle of elevation of the top of the tower is 7° .

- (a) How far is the hotel from the tower?
 (b) What is the height of the tower?

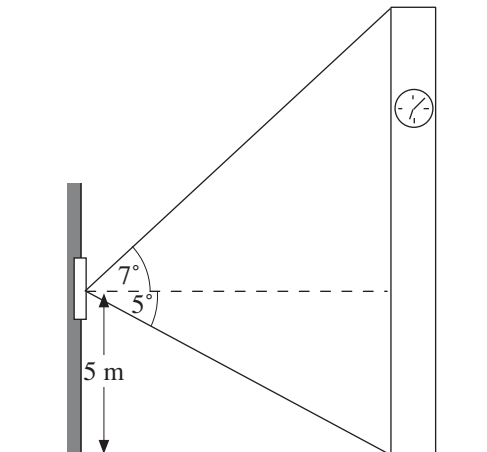

10. A radar operator notes that an aeroplane is at a distance of 2000 metres and at a height of 800 metres. Find the angle of elevation. A little while later the distance has reduced to 1200 metres, but the height remains 800 metres. How far has the aeroplane moved?

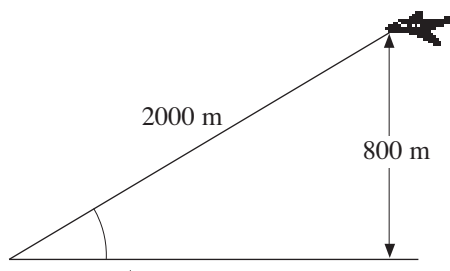

11. The diagram represents a triangular roof frame ABC with a window frame EFC. BDC and EF are horizontal and AD and FC are vertical.

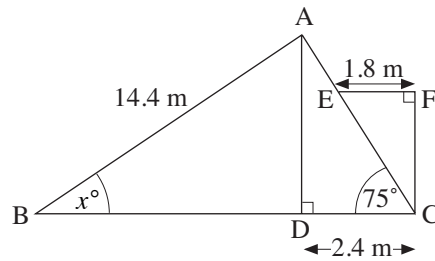

- Calculate the height AD.
- Calculate the size of the angle marked x° in the diagram.
- Calculate FC.

12. Two ships B and C are both due east of a point A at the base of a vertical cliff. The cliff is 130 metres high. The ship at C is 350 metres from the bottom of the cliff.

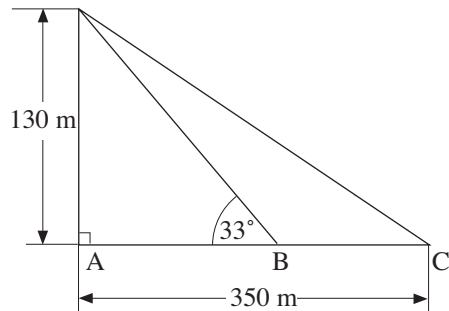

- Calculate the distance from the top of the cliff to the ship at C.
 - Calculate the angle of depression from the top of the cliff to the ship at C.
- The angle of elevation of the top of the cliff from the ship at B is 33° . Calculate the distance BC.

35.2 Sine and Cosine Rules

In the triangle ABC, the side opposite angle A has length a , the side opposite angle B has length b and the side opposite angle C has length c .

The *sine rule* states

$$\frac{\sin A}{a} = \frac{\sin B}{b} = \frac{\sin C}{c}$$

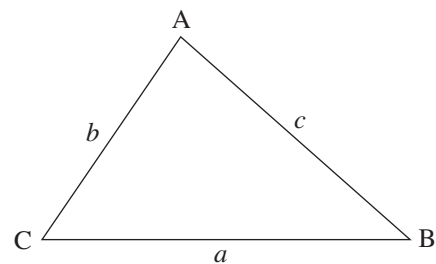

Proof of Sine Rule

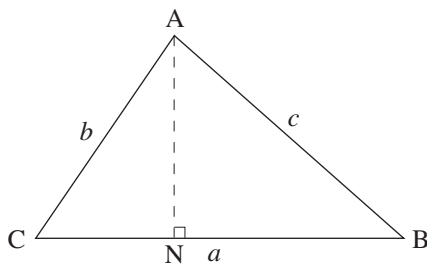

If you construct the perpendicular from vertex A to meet side CB at N, then

$$\begin{aligned} AN &= c \sin B && \text{(from } \triangle ABN) \\ &= b \sin C && \text{(from } \triangle ACN) \end{aligned}$$

Hence

$$c \sin B = b \sin C \Rightarrow \frac{\sin B}{b} = \frac{\sin C}{c}$$

similarly for $\frac{\sin A}{a}$.

The *cosine rule* states

$$a^2 = b^2 + c^2 - 2bc \cos A$$

$$b^2 = c^2 + a^2 - 2ca \cos B$$

$$c^2 = a^2 + b^2 - 2ab \cos C$$



Proof of Cosine Rule

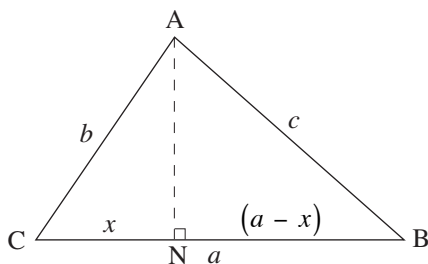

If $CN = x$, then $NB = a - x$ and

$$\begin{aligned} c^2 &= AN^2 + (a - x)^2 \quad \text{when } x = CN \\ &= (b \sin C)^2 + (a - b \cos C)^2, \quad \text{since } x = b \cos C \\ &= b^2 \sin^2 C + b^2 \cos^2 C - 2ab \cos C + a^2 \\ &= b^2 (\sin^2 C + \cos^2 C) + a^2 - 2ab \cos C \end{aligned}$$

$$\text{i.e. } c^2 = b^2 + a^2 - 2ab \cos C, \quad \text{since } \sin^2 C + \cos^2 C = 1$$



Worked Example 1

Find the unknown angles and side length of the triangle shown.

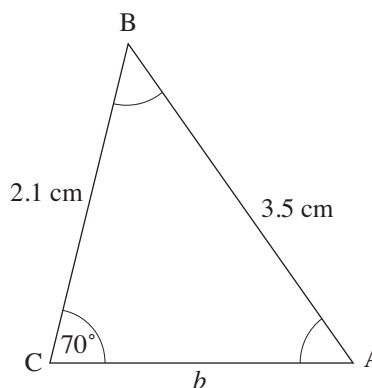

Solution

Using the sine rule,

$$\frac{\sin A}{2.1} = \frac{\sin 70^\circ}{3.5} = \frac{\sin B}{b}$$

From the first equality,

$$\sin A = \frac{2.1 \times \sin 70^\circ}{3.5} = 0.5638$$

$$A = 34.32^\circ$$

Since angles in a triangle add up to 180° ,

$$B = 180^\circ - 70^\circ - A = 75.68^\circ$$

From the sine rule,

$$\frac{\sin 70^\circ}{3.5} = \frac{\sin B}{b}$$

$$b = \frac{3.5 \times \sin B}{\sin 70^\circ}$$

$$= \frac{3.5 \times \sin 75.68^\circ}{\sin 70^\circ}$$

$$= 3.61 \text{ cm}$$



Worked Example 2

Find two solutions for the unknown angles and side of the triangle shown.



Solution

Using the sine rule,

$$\frac{\sin A}{a} = \frac{\sin B}{6} = \frac{\sin 42^\circ}{5}$$

From the second equality,

$$\sin B = \frac{6 \times \sin 42^\circ}{5} = 0.8030$$

A graph of $\sin x$ shows that between 0° and 180° there are two solutions for B.

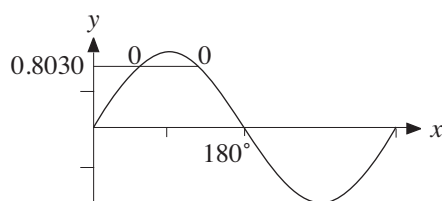

These solutions are $B = 53.41^\circ$ and, by symmetry, $B = 180 - 53.41$

$$= 126.59^\circ$$

Solving for angle A we have

$$A = 180^\circ - 42^\circ - B$$

$$\text{when } B = 53.41^\circ, \quad A = 84.59^\circ$$

$$\text{when } B = 126.59^\circ, \quad A = 11.41^\circ$$

From the sine rule,

$$a = \frac{6 \times \sin A}{\sin B}$$

For $A = 84.59^\circ$, $B = 53.41^\circ$, $a = 7.44$ cm

For $A = 11.41^\circ$, $B = 126.59^\circ$, $a = 1.48$ cm

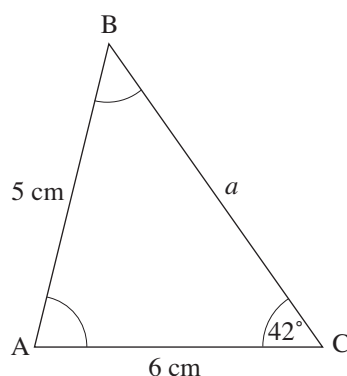

Worked Example 3

Find the unknown side and angles of the triangle shown.



Solution

To find a , use the cosine rule:

$$a^2 = 4.9^2 + 3.7^2 - 2 \times 4.9 \times 3.7 \times \cos 65^\circ$$

$$a^2 = 22.3759$$

$$a = 4.73 \quad (\text{to 2 d.p.})$$

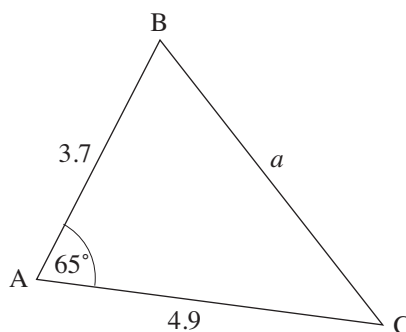

To find the angles, use the sine rule:

$$\frac{\sin 65^\circ}{a} = \frac{\sin B}{4.9} = \frac{\sin C}{3.7}$$

$$\sin B = \frac{4.9 \times \sin 65^\circ}{a} = \frac{4.9 \times \sin 65^\circ}{4.73} = 0.9389$$

$$B = 69.86^\circ$$

$$\sin C = \frac{3.7 \times \sin 65^\circ}{a} = \frac{3.7 \times \sin 65^\circ}{4.73} = 0.7090$$

$$C = 45.15^\circ \text{ (alternatively, use } A + B + C = 180^\circ \text{ to find } C)$$

Checking, $A + B + C = 65^\circ + 69.86^\circ + 45.15^\circ = 180.01^\circ$. The three angles should add to 180° ; the extra 0.01° is due to rounding errors.



Worked Example 4

The diagram below, **not drawn to scale**, shows the journey of a ship which sailed from Port A to Port B and then to Port C. Port B is located 32 km due West of Port A and Port C is 45 km from Port B on a bearing of 040° .

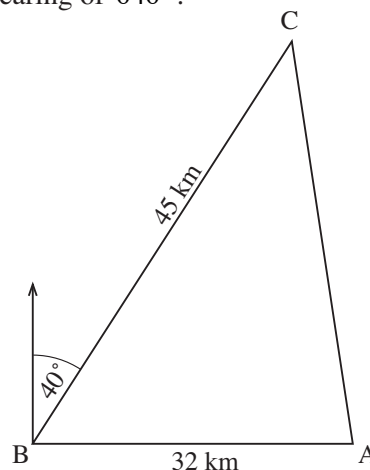

Calculate, giving your answers correct to 3 significant figures

- the distance AC
- the bearing of Port C from Port A. (CXC)



Solution

- Using the COSINE rule,

$$AC^2 = BC^2 + BA^2 - 2 \times BC \times BA \times \cos \hat{CBA}$$

As angle $CBA = 90^\circ - 40^\circ$, then

$$AC^2 = 32^2 + 45^2 - 2 \times 32 \times 45 \times \cos 50^\circ$$

$$\approx 1197.77$$

$$AC \approx 34.6088$$

$$= 34.6 \text{ to 3 significant figures}$$

(b)

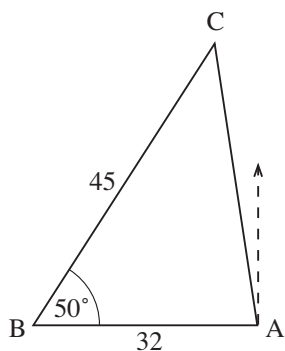

The bearing of C from A is

$$270^\circ + \text{angle BAC}$$

$$\text{Using the SINE rule, } \frac{\sin \text{BAC}}{45} = \frac{\sin 50^\circ}{34.6088}$$

$$\sin \text{BAC} = \frac{45 \times \sin 50^\circ}{34.6088}$$

$$\approx 0.9960$$

$$\text{So angle BAC} \approx 84.903^\circ$$

$$= 84.9^\circ \text{ to 3 significant figures}$$

Hence the bearing of Port A from Port B is

$$270^\circ + 84.9^\circ = 354.9^\circ$$

$$= 355^\circ \text{ to 3 significant figures}$$

Some important values of $\sin \theta$, $\cos \theta$ and $\tan \theta$ are shown in this table.

θ	$\sin \theta$	$\cos \theta$	$\tan \theta$
0°	0	1	0
30°	$\frac{1}{2}$	$\frac{\sqrt{3}}{2}$	$\frac{1}{\sqrt{3}}$
45°	$\frac{1}{\sqrt{2}}$	$\frac{1}{\sqrt{2}}$	1
60°	$\frac{\sqrt{3}}{2}$	$\frac{1}{2}$	$\sqrt{3}$
90°	1	0	infinite

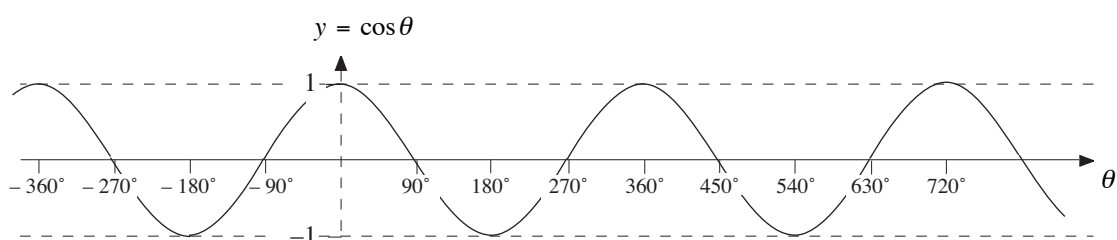
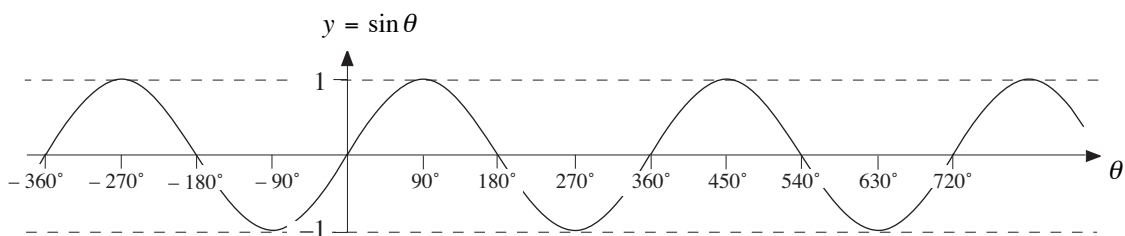
The graphs of $\sin \theta$ and $\cos \theta$ for any angle are shown in the following diagrams.

The graphs are examples of *periodic functions*. Each basic pattern repeats itself every 360° . We say that the *period* is 360° .



Worked Example 5

An oil tanker leaves Town X, and travels on a bearing of 050° to Town Z, 50 km away. The tanker then travels to Town Y, 70 km away, on a bearing of 120° .

- Draw a carefully labelled diagram of the tanker's journey, clearly showing the North line.
- Calculate the distance of Y from X, giving your answer to 3 significant figures.
- On your diagram, mark the angle that shows the bearing of X from Y.
 - Calculate the bearing of X from Y, giving your answer to the nearest degree.

(CXC)



Solution

(a)

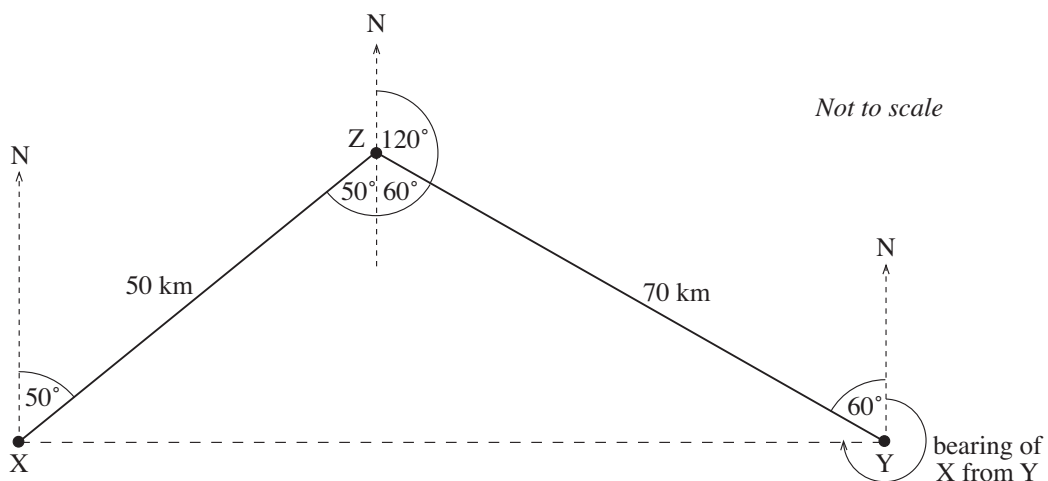

- (b) In triangle XZY, angle $XZY = 50^\circ + 60^\circ = 110^\circ$
so, using the cosine rule,

$$\begin{aligned} XY^2 &= 50^2 + 70^2 - 2 \times 50 \times 70 \times \cos 110^\circ \\ &= 2500 + 4900 - 7000 \cos 110^\circ \\ &\approx 7400 - 7000 \times (-0.3420) \\ &\approx 9794.14 \end{aligned}$$

$$\begin{aligned} XY &\approx 98.965 \\ &= 99.0 \text{ to 3 significant figures.} \end{aligned}$$

- (c) (i) As marked on diagram.
- (ii) We need to find the angle ZYX to determine the bearing of X from Y.

In triangle ZYX, using the sine rule,

$$\frac{\sin ZYX}{50} \approx \frac{\sin 110^\circ}{99.0}$$

$$\sin ZYX \approx 0.4748$$

$$\text{angle } ZYX \approx 28.34^\circ = 28^\circ \text{ to the nearest degree}$$

Hence the bearing of X from Y

$$= 360^\circ - (60^\circ + 28^\circ)$$

$$= 272^\circ$$



Worked Example 6

Find the shaded angle in the triangle shown.



Solution

Using the cosine rule,

$$25^2 = 16^2 + 13^2 - 2 \times 16 \times 13 \cos x$$

Rearranging,

$$2 \times 16 \times 13 \cos x = 16^2 + 13^2 - 25^2$$

$$416 \cos x = -200$$

$$\cos x = \frac{-25}{52}$$

$$x \approx \cos^{-1}\left(\frac{-25}{52}\right)^\circ$$

$$= 118.7^\circ \text{ to 1 decimal place}$$

using the **(SHIFT)** and **(COS)** buttons on a calculator.

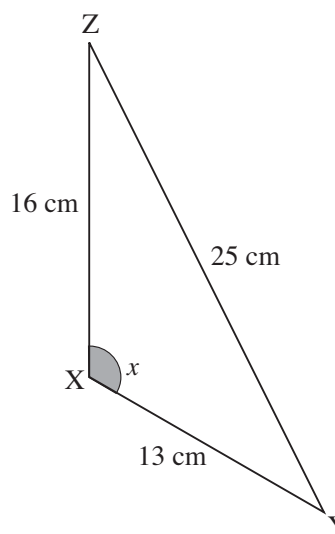

Note

As $\cos x$ is negative, the angle will be obtuse ($90^\circ < x < 180^\circ$).



Exercises

1. For each of the triangles, find the unknown angle marked θ .

(a)

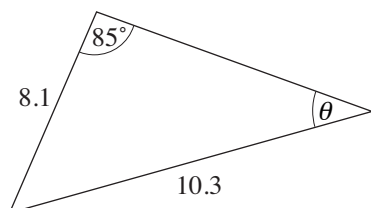

(b)

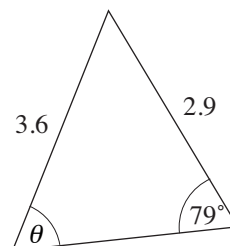

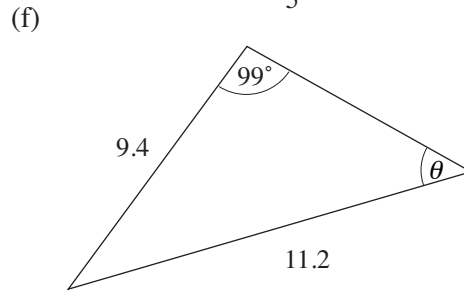
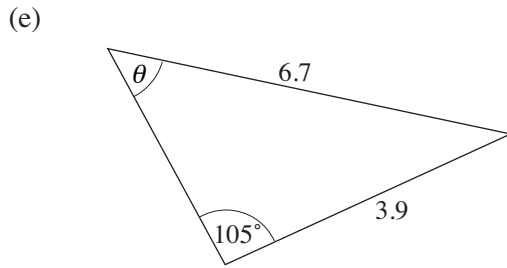
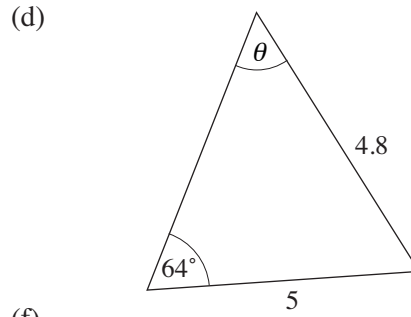
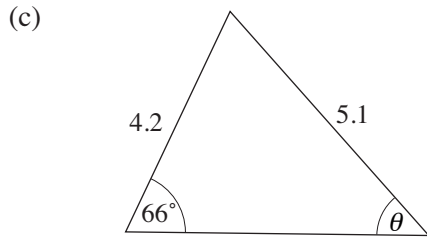

2. For each triangle, find the unknown side marked a , b or c .

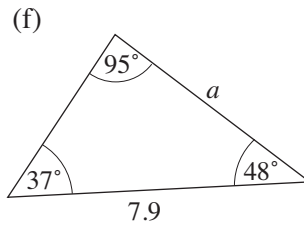
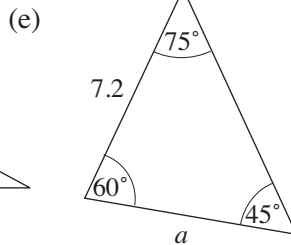
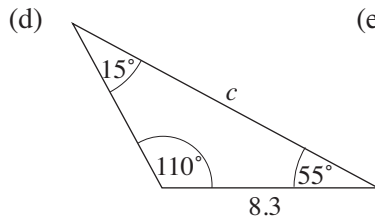
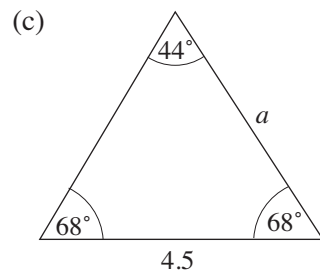
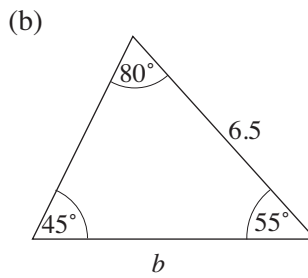
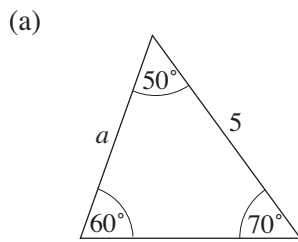

3. For each of the triangles, find the unknown angles and sides.

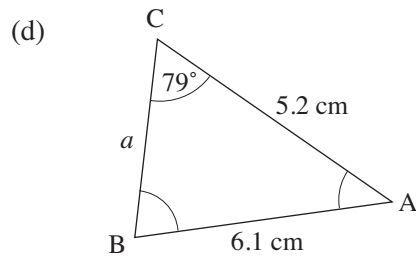
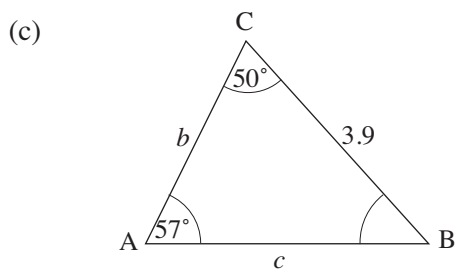
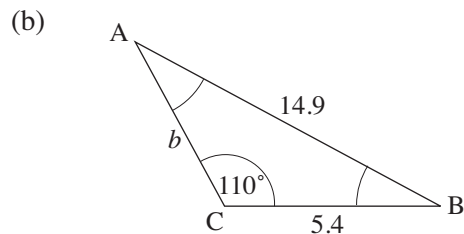
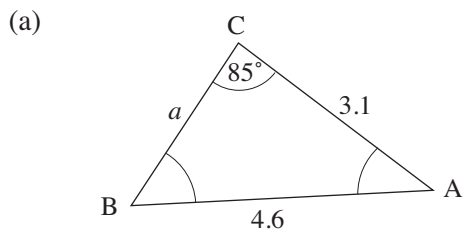

4. Which of the following triangles could have *two* solutions?

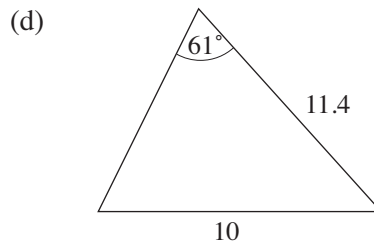
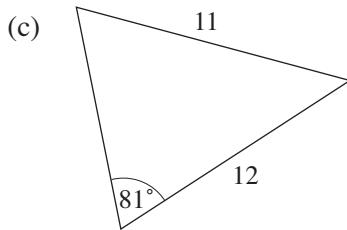
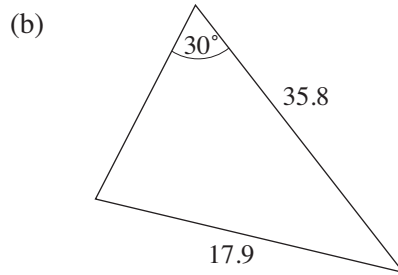
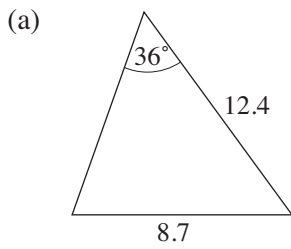

5. Find the remaining angles and sides of the triangle ABC if $A = 67^\circ$, $a = 125$ and $c = 100$.

6. Find the remaining angles and sides of the triangle ABC if $B = 81^\circ$, $b = 12$ and $c = 11$.

7. For each of the following triangles, find the unknown angles and sides.

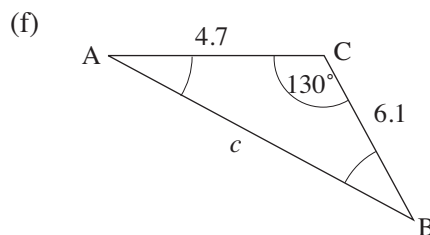
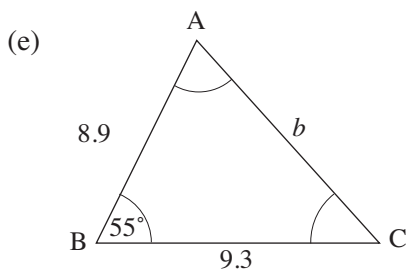
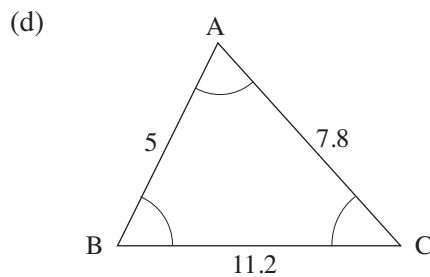
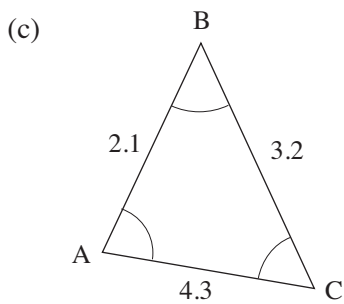
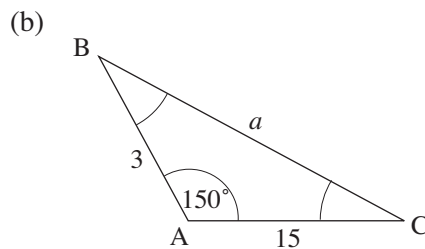
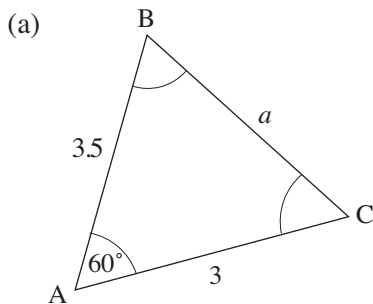

8. To calculate the height of a church tower, a surveyor measures the angle of elevation of the top of the tower from two points 50 metres apart. The angles are shown in the diagram.

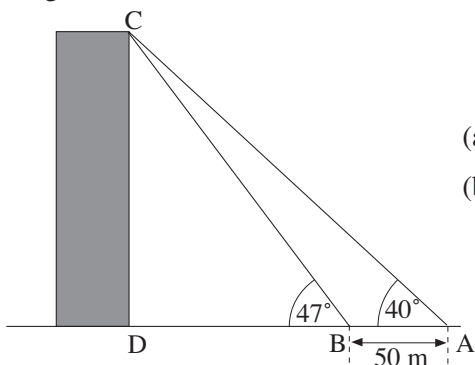

- (a) Calculate the distance BC.
 (b) Hence calculate the height of the tower CD.

9. The angles of elevation of a hot air balloon from two points, A and B, on level ground, are 24.2° and 46.8° , respectively.

The points A and B are 8.4 miles apart, and the balloon is between the points in the same vertical plane. Find the height of the balloon above the ground.

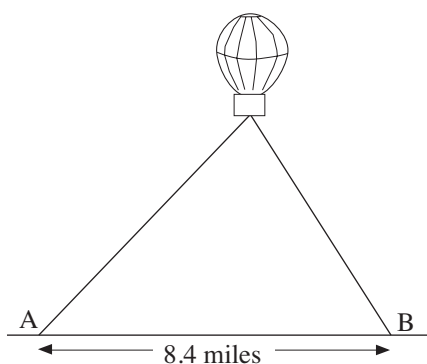

10. The diagram shows a crane working on a wharf. AB is vertical.

- (a) Find the size of angle ABC.
 (b) Find the height of point C above the wharf.

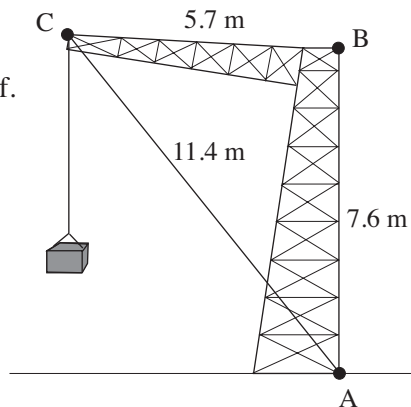

11. The rectangular box shown in the diagram has dimensions 10 cm by 8 cm by 6 cm. Find the angle θ formed by a diagonal of the base and a diagonal of the 8 cm by 6 cm side.

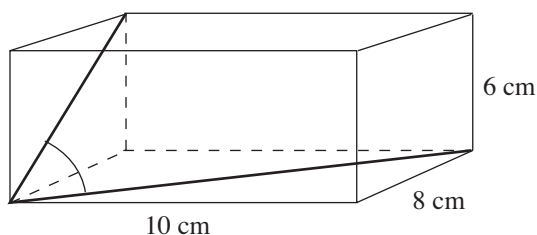

12. (a) Calculate the length KB.
 (b) Calculate the size of the angle NKB.

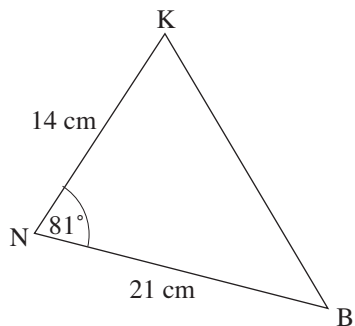

13. Stewart Town is 35 km due north of Williamsfield, Manchester.

Ipswich, St. Elizabeth, is 40 km from Williamsfield and 45 km from Stewart Town.

Calculate the bearing of Ipswich from Williamsfield.

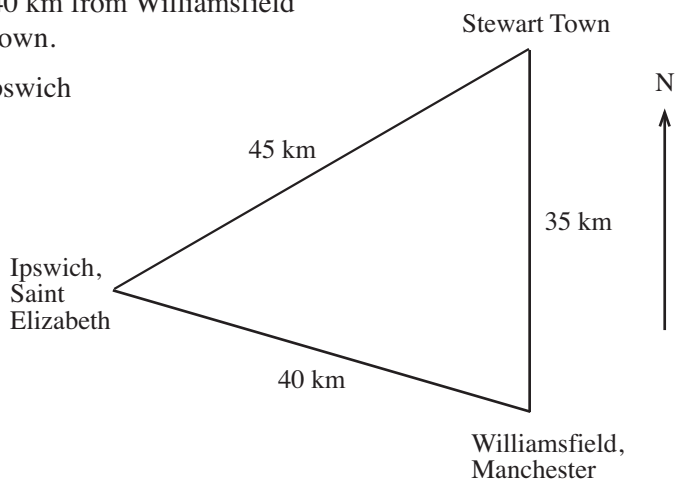

14. In triangle ABC, $AC = 12.6$ cm ,
 $BC = 11.2$ cm and angle $B = 54^\circ$.
 The lengths AC and BC are correct to the nearest millimetre and angle B is correct to the nearest degree. Use the sine rule

$$\frac{\sin A}{a} = \frac{\sin B}{b}$$

to calculate the smallest possible value of angle A.

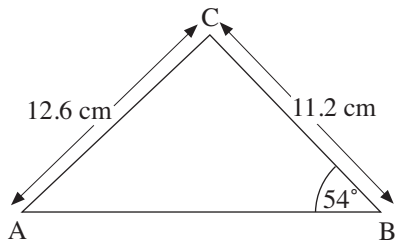

15. The banks of a river are straight and parallel. To find the width of the river, two points, A and B, are chosen 50 metres apart. The angles made with a tree at C on the opposite bank are measured as angle $CAB = 56^\circ$, angle $CBA = 40^\circ$. Calculate the width of the river.

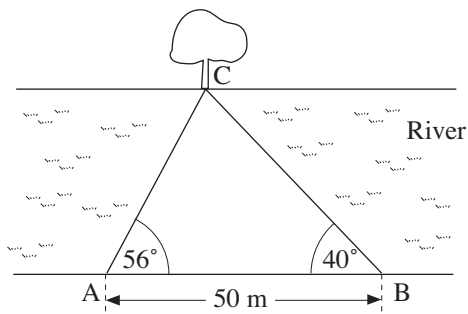

35.3 Application: Area of Any Triangle

An important application of trigonometry is that of finding the area of a triangle with side lengths a and b and included angle θ .

The area (A) is given by $\frac{1}{2}ab\sin\theta^\circ$.

$$A = \frac{1}{2}ab\sin\theta$$

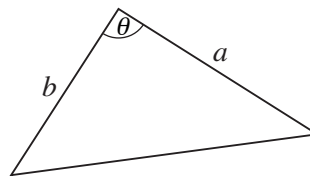

Proof

If you construct the perpendicular from the vertex B to AC , then its length, p , is given by

$$p = a \sin \theta$$

Thus the area of ABC is given by

$$\text{area} = \frac{1}{2} \times \text{base} \times \text{height}$$

$$= \frac{1}{2} \times b \times p$$

$$= \frac{1}{2} \times b \times (a \sin \theta)$$

$$= \frac{1}{2} ab \sin \theta$$

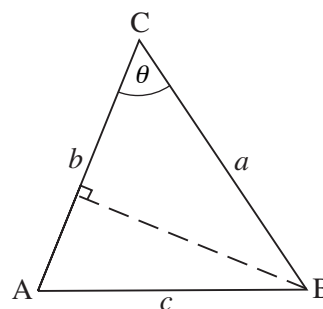

as required.



Worked Example 1

The diagram shows a circle of radius 64 cm.

The length of the chord AB is 100 cm.

- Find the angle θ , to 2 d.p.
- Find the area of triangle OAB .

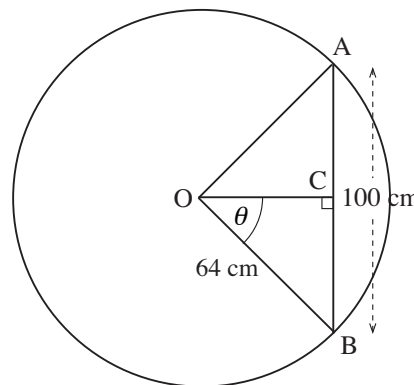

Solution

- If $AB = 100$ cm then, by symmetry, $BC = 50$ cm.

$$\sin \theta = \frac{50}{64}$$

$$\theta = 51.38^\circ$$

- The area of the triangle OAB is $\frac{1}{2} \times 64^2 \times \sin 2\theta = 1997 \text{ cm}^2$

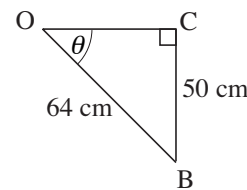



Worked Example 2

Given that $\sin \theta = \frac{\sqrt{3}}{2}$, $0^\circ \leq \theta \leq 90^\circ$

- (a) Express in fractional or surd form the value of $\cos \theta$.
- (b) Show that the area of triangle CDE is $150\sqrt{3}$ square units, where $CD = 30$ units and $DE = 20$ units.

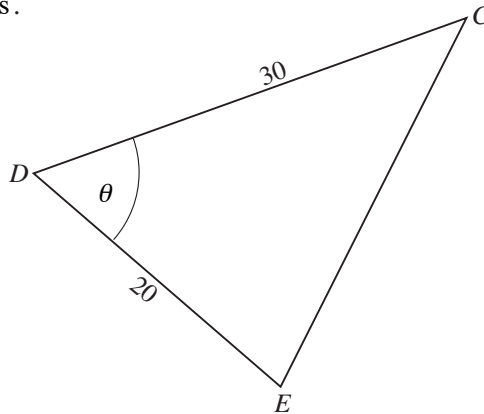

- (c) Calculate the length of the side EC . (CXC)



Solution

$$\sin^2 \theta + \cos^2 \theta = 1$$

so

$$\begin{aligned} \cos^2 \theta &= 1 - \left(\frac{\sqrt{3}}{2}\right)^2 \\ &= 1 - \frac{3}{4} \\ &= \frac{1}{4} \end{aligned}$$

Hence

$$\cos \theta = \frac{1}{2}$$

[An alternative approach is to consider the right angled triangle, as shown.]

If the lengths

$$BC = \sqrt{3}, AC = 2$$

then clearly $\sin \theta = \frac{\sqrt{3}}{2}$. We can find the length AB :

$$\begin{aligned} AB^2 &= AC^2 - CB^2 \quad (\text{Pythagoras}) \\ &= 4 - 3 = 1 \end{aligned}$$

$$\text{So } AB = 1 \text{ and } \cos \theta = \frac{AB}{AC} = \frac{1}{2}]$$

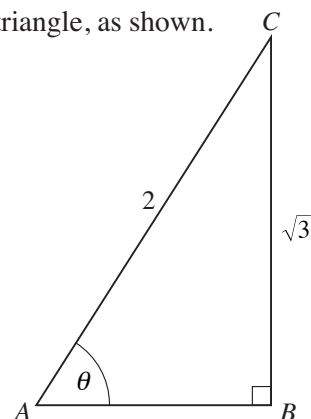

(b) In the given triangle,

$$\begin{aligned} \text{Area} &= \frac{1}{2} \times CD \times DE \sin \theta \\ &= \frac{1}{2} \times 30 \times 20 \times \frac{\sqrt{3}}{2} \\ &= 150\sqrt{3} \end{aligned}$$

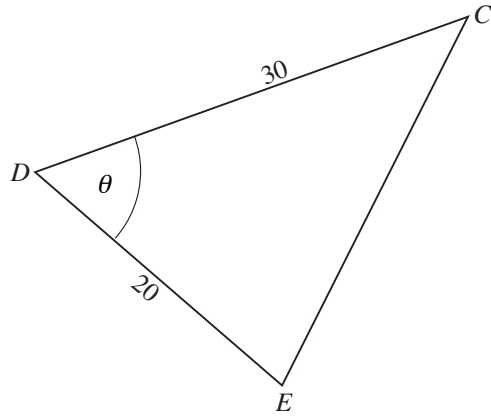

(c) We can find the length EC using the cosine rule, namely

$$\begin{aligned} EC^2 &= DE^2 + DC^2 - 2 \times DE \times DC \times \cos \theta \\ &= 20^2 + 30^2 - 2 \times 20 \times 30 \times \frac{1}{2} \\ &= 400 + 900 - 600 \\ &= 700 \\ EC &\approx 26.5 \end{aligned}$$



Exercises

1. Find the area of the shaded region in each of the following figures.

(a)

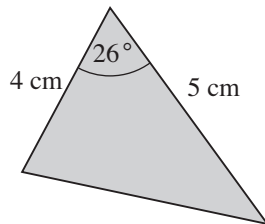

(b)

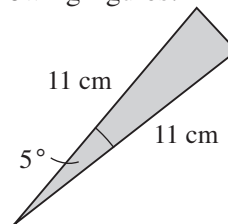

2. Find the area of the shaded region.

(a)

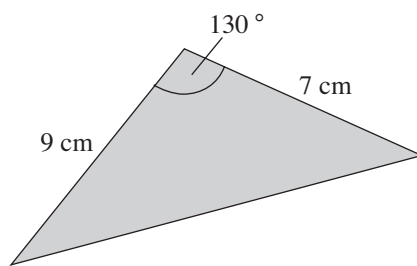

(b)

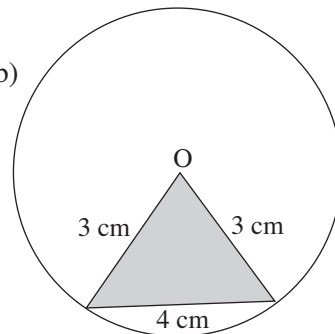

3. Find the area of the shaded region.

(a)

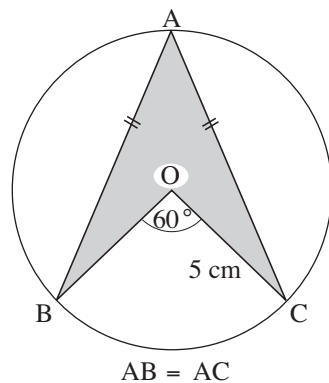

(b)

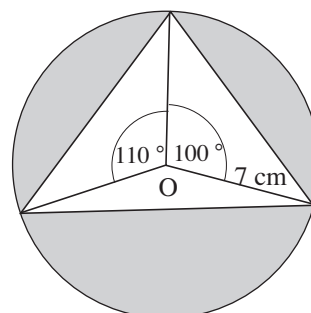

4.

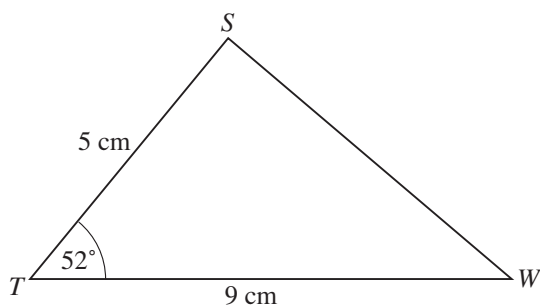

In the diagram above, **not drawn to scale**, $ST = 5$ cm, $TW = 9$ cm and $\angle STW = 52^\circ$.

Calculate

- the length of SW
- the area of $\triangle STW$. (CXC)

5.

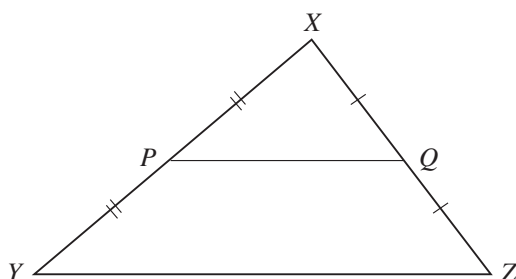

In the diagram above, **not drawn to scale**, P and Q are midpoints of the sides XY and XZ of triangle XYZ . Given that $XP = 7.5$ cm, $XQ = 4.5$ cm and the area of triangle $XPQ = 13.5$ cm², calculate

- the size of angle PXQ , expressing your answer correct to the nearest degree.
- the area of triangle YXZ . (CXC)

6. On the diagram below, **not drawn to scale**, $TU = 8$ m, $TW = 10$ m, $VW = 11$ m, angle $UTW = 60^\circ$ and angle $WUV = 40^\circ$.

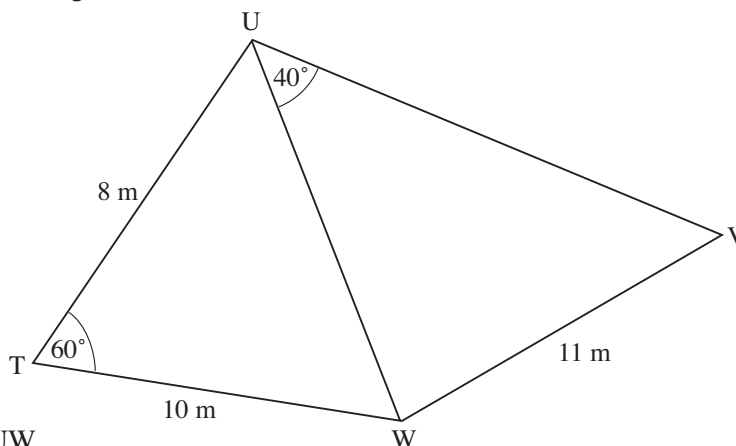

Calculate

- the length of UW
- the size of the angle UVW
- the area of triangle TUW . (CXC)